

SPIRIT



CT980 Treadmill OWNER'S MANUAL

Please carefully read this entire manual before operating your new treadmill.

TABLE OF CONTENTS

Important Safety Instructions.....	2
Important Electrical Instructions.....	4
Important Operation Instructions.....	5
Getting on / off your Treadmill.....	6
Assembly Instructions.....	7
Console Operation.....	13
Using a Heart Rate Transmitter.....	27
General Maintenance.....	28
Troubleshooting.....	31
Exploded View Diagram and Parts List.....	32

IMPORTANT SAFETY INSTRUCTIONS

WARNING - Read all instructions before using this exercise equipment.

DANGER - To reduce the risk of electric shock disconnect your treadmill from the electrical outlet prior to cleaning and/or service work.

WARNING - To reduce the risk of burns, fire, electric shock, or injury to persons, install the treadmill on a flat level surface with access to a 230 Vac, 15 amp grounded outlet. Heart rate monitoring systems may be inaccurate. Over exercising may result in serious injury or death. If you feel faint stop exercising immediately.

DO NOT USE AN EXTENSION CORD UNLESS IT IS 2m m² OR BETTER, WITH ONLY ONE OUTLET ON THE END. The treadmill should be the only exercise equipment in the circuit in which it is connected. **DO NOT ATTEMPT TO DISABLE THE GROUNDED PLUG BY USING IMPROPER ADAPTERS, OR IN ANY WAY MODIFY THE CORD SET.** A serious shock or fire hazard may result along with computer malfunctions.

DO NOT USE AN EXTENSION CORD UNLESS IT IS A 12 AWG OR BETTER, WITH ONLY ONE OUTLET ON THE END:

- **Max. user's weight.: 205 kg**
- Do not operate treadmill on deeply padded, plush or shag carpet. Damage to both carpet and treadmill may result.
- Keep children away from the treadmill. There are obvious pinch points and other caution areas that can cause harm.
- Keep hands away from all moving parts.
- Never operate the treadmill if it has a damaged cord or plug. If the treadmill is not working properly, call your dealer.
- Keep the cord away from heated surfaces.
- Do not operate where aerosol spray products are being used or where oxygen is being administered. Sparks from the motor may ignite a highly gaseous environment.
- Never drop or insert any object into any openings.
- Do not use outdoors.
- To disconnect, turn all controls to the off position and then remove the plug from the outlet.
- Do not attempt to use your treadmill for any purpose other than for the purpose it is intended.
- The hand pulse sensors are not medical devices. Various factors, including the user's movement, may affect the accuracy of heart rate readings. The pulse sensors are intended only as exercise aids in determining heart rate trends in general.
- Wear proper shoes. High heels, dress shoes, sandals or bare feet are not suitable for use on your treadmill. Quality athletic shoes are recommended to avoid leg fatigue.
- This exercise equipment is not intended for use by persons (including children) with reduced physical, sensory or mental capabilities, or lack of experience and knowledge, Unless they are being supervised and given instruction concerning use of the exercise equipment by a person responsible for their safety.

- This exercise equipment can be used by children aged from 8 years and above and persons with reduced physical, sensory or mental capabilities or lack of experience and knowledge if they have been given supervision or instruction concerning use of the exercise equipment in a safe way and understand the hazards involved. Children shall not play with the exercise equipment. Cleaning and user maintenance shall not be made by children without supervision.
- Children should be supervised to ensure that they do not play with the exercise equipment.
- Suitable information about replacement parts that could affect the safe use of the treadmill
- The following statement: "Noise emission under load is higher than without load."
- If applicable, the value of the A-weighted emission sound pressure level at the trainer's ear
- Don't change any component by yourself, you may get injured or damage the treadmill Below mentioned sound pressure level is measured under the condition when the trainer is operating with 5m/h or 8 km/h with no load. Sound pressure level (dB) < 70dB. Noise emission under load is higher than without load.
- Please make sure that the power-supply cord and adapter placed in dry area and kept away from heat.
- **WARNING:** Injuries to health may result from incorrect or excessive training.
- This exercise equipment is not intended for use by persons with reduced physical, sensory or mental capabilities, or lack of experience and knowledge.
- Before beginning this or any exercise program, consult a physician. This is especially important for persons over the age of 35 or persons with pre-existing health conditions.
- Close supervision is necessary when this exercise equipment is used by or near children, invalids, or disabled persons.

- **WARNING** – Heart rate monitoring systems may be inaccurate. Over exercising may result in serious injury or death. If you feel faint stop exercising immediately.

- **WARNING** – The equipment shall be installed on a stable base and properly leveled.

- **WARNING**–
 1. Examine the machine on a regular basis for needed repairs or replacement of damaged or worn parts.
 2. Replace defective components immediately and/or keep the equipment out of use until repair.
 3. The components which are most susceptible to wear: running belt, driver motor, incline motor.
 4. Please keep the Safety key in safe place when user stop workout that in order to prevent the children use the treadmill.
 5. If the treadmill have any problem or shutdown (ex: change the belt, running deck, console...), please contract with service center.

**Remove tether cord after use to prevent unauthorized treadmill operation.
SAVE THESE INSTRUCTIONS - THINK SAFETY!**

IMPORTANT ELECTRICAL INSTRUCTIONS

WARNING!

Route the power cord away from any moving part of the treadmill including the elevation mechanism and transport wheels.

NEVER remove any cover without first disconnecting AC power. If voltage varies by ten percent (10%) or more, the performance of your treadmill may be affected. **Such conditions are not covered under your warranty.** If you suspect the voltage is low, contact your local power company or a licensed electrician for proper testing.

Do not attempt any servicing or adjustments other than those described in this manual. All else must be left to trained service personnel familiar with electro-mechanical equipment and authorized under the laws of the country in question to carry out maintenance and repair work.

NEVER expose this treadmill to rain or moisture. This product is **NOT** designed for use outdoors, near a pool or spa, or in any other high humidity environment. The temperature specification is 40 degrees c, and humidity is 95%, non-condensing (no water drops forming on surfaces).

Circuit breakers: Avoid AFCI/GFCI circuit breakers if possible. These breakers may trip occasionally during exercise because of the high inrush currents of the treadmill drive electronics and motor. This is an issue that affects all treadmill brands.

New laws in your area may require these breakers. If you do have these breakers and outlets in your home, and are experiencing nuisance tripping, you should check if there are any other devices plugged into the same circuit. Some examples of devices that may also cause tripping are fluorescent lights with electronic ballasts, coffee maker, space heater, hair drier. Optimally the treadmill should be the only device plugged into the circuit.

Our treadmills have surge suppressors built in to help avoid nuisance tripping. We have tested several AFCI/GFCI breakers and outlets with our products. Brands we have tested are: Eaton (Cutler Hammer Series), Leviton (Smart lock pro) and Schneider Electric (Canadian home series). These breakers do not trip in our testing, when connected to our treadmills, as long as no other devices are plugged into the same circuit.

Grounding Instructions

This product must be grounded. If the treadmill's electrical system should malfunction or breakdown grounding provides a path of least resistance for electric current, reducing the risk of electric shock. This product is equipped with a cord having an equipment-grounding plug. The plug must be plugged into an appropriate outlet that is properly installed and grounded in accordance with all local codes and ordinances.

DANGER - Improper connection of the equipment-grounding conductor can result in a risk of electric shock. Check with a qualified electrician or serviceman if you are in doubt as to whether the product is properly grounded. Do not modify the plug provided with the product if it will not fit the outlet; have a proper outlet installed by a qualified electrician.

This product is for use on a nominal 230-volt circuit, and has a grounding plug that looks like the plug illustrated below. A temporary adapter that looks like the adapter illustrated below may be used to connect this plug to a 2-pole receptacle as shown below if a properly grounded outlet is not available. The temporary adapter should be used only until a properly grounded outlet, (shown below) can be installed by a qualified electrician. The green colored rigid ear-lug, or the like, extending from the adapter, must be connected to a permanent ground such as a properly grounded outlet box cover. Whenever the adapter is used, it must be held in place by a metal screw.

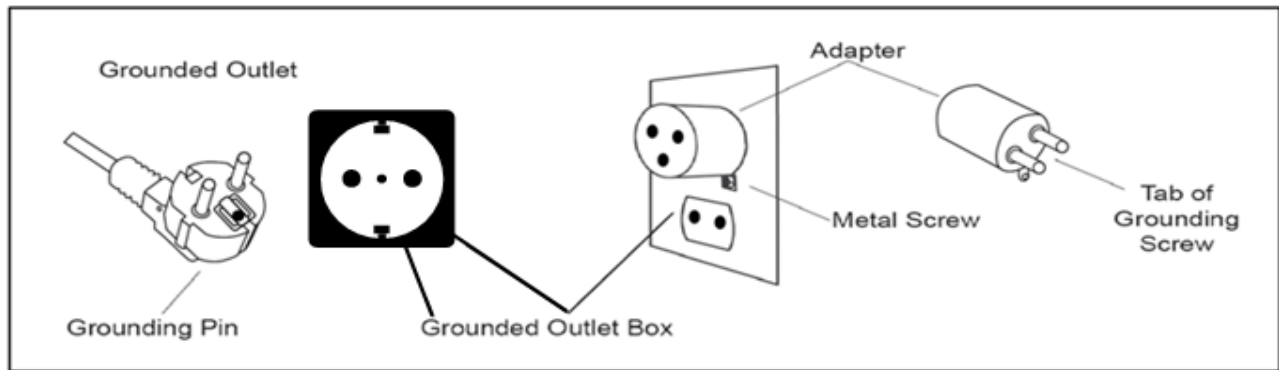

IMPORTANT OPERATION INSTRUCTIONS

- **NEVER** operate this treadmill without reading and completely understanding the results of any operational change you request from the computer.
- Understand that changes in speed and incline do not occur immediately. Set your desired speed on the computer console and release the adjustment key. The computer will obey the command gradually.
- **NEVER** use your treadmill during an electrical storm. Surges may occur in your household power supply that could damage treadmill components.
- Use caution while participating in other activities while walking on your treadmill; such as watching television, reading, etc. These distractions may cause you to lose balance or stray from walking in the center of the belt; which may result in serious injury.
- **NEVER** mount or dismount the treadmill while the belt is moving. Treadmills start with at a very low speed and it is unnecessary to straddle the belt during start up. Simply standing on the belt during slow acceleration is proper after you have learned to operate the unit.
- Always hold on to a handrail or hand bar while making control changes (incline, speed, etc.).
- Do not use excessive pressure on console control keys. They are precision set to function properly with little finger pressure. Pushing harder is not going to make the unit go faster or slower. If you feel the buttons are not functioning properly with normal pressure contact your dealer.

GETTING ON / OFF YOUR TREADMILL

IMPORTANT

The treadmill comes with Handles.

Always hold the Handlebar when getting on and off the treadmill.

First time users should familiarize themselves with using the treadmill by using the Handlebar first and then progressing to the Dual Action Handles.

Once you have familiarized yourself with using the treadmill, you can progress to running without using the handles to provide a total body workout.

*Caution should always be taken when getting on and off any exercise machine.
Please follow the safety steps below.*



Ensure the belt is stationary and grasp the Stationary Handlebar with hands.

Place your both foot on the running belt.

Please slowly increase the speed of treadmill . Get balanced and begin your workout.

Important

To get off, come to a complete stop and reverse the procedure.

Always wear rubber-soled shoes, such as tennis shoes.

It is recommended that you keep at least one hand on the Stationary Handlebar at all times, especially when getting on or off. If you are performing a walking action with your arms, ensure you are well balanced.

All equipment should be set-up and operated on solid, level surfaces.

Correct Position

Your body should be in an upright position so that your back is straight. Keep your head up to minimize neck and upper back strain.

Always try and use the treadmill in a rhythmical and smooth motion. If you find yourself feeling uncomfortable, or experience a surging type feeling, there is probably too much tension.

ASSEMBLY INSTRUCTIONS

UNPACKING

1. Cut the straps and open box.
2. Locate the hardware package. The hardware is separated into four steps. Remove the tools first. Remove the hardware for each step as needed to avoid confusion. The numbers in the instructions that are in parenthesis (#) are the item number from the assembly drawing for reference.
3. Assembly of the machine needs to be performed by trained service personnel familiar with electro-mechanical equipment and authorized under the laws of the country in question to carry out assembly, maintenance and repair work.

ASSEMBLY TOOLS

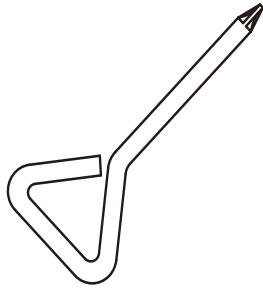

#112. Phillips Head Screw driver (1 pc)

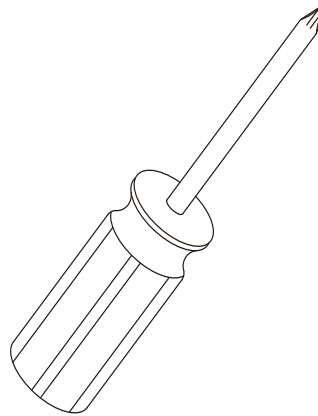

#111. Phillips Head Screw driver (1 pc)

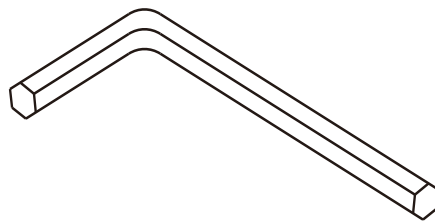

#110. 8mm L Allen Wrench (1 pc)

STEP1

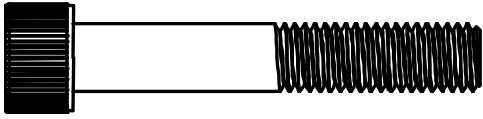

#65 - M10 × 60mm
Socket Head Cap Bolt
(10pcs)

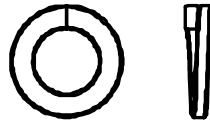

#79 - Ø10 × 2T
Spring Washer
(10pcs)

STEP2

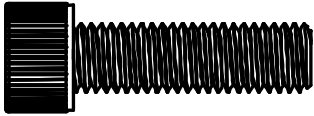

#63 - M10 × 35mm
Socket Head Cap Bolt
(6pcs)

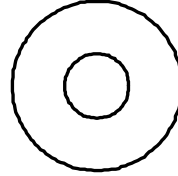

#74 - Ø3/8" × 25 × 3T
Flat Washer
(6pcs)

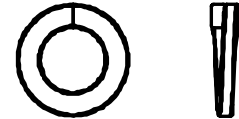

#79 - Ø10 × 2T
Spring Washer
(6pcs)

STEP3



#158 - M5×10mm
Phillips Head Screw
(4pcs)



#159 - M5×15mm
Phillips Head Screw
(4pcs)

STEP4



#158 - M5 × 10mm
Phillips Head Screw
(4pcs)



#69 - M5 × 25m/m
Phillips Head Screw
(2pcs)



#83 - 3.5 × 12m/m
Sheet Metal Screw
(18pcs)

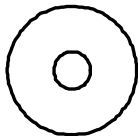

#75 - Ø5.5 × Ø19 × 1.5T
Flat Washer
(8pcs)

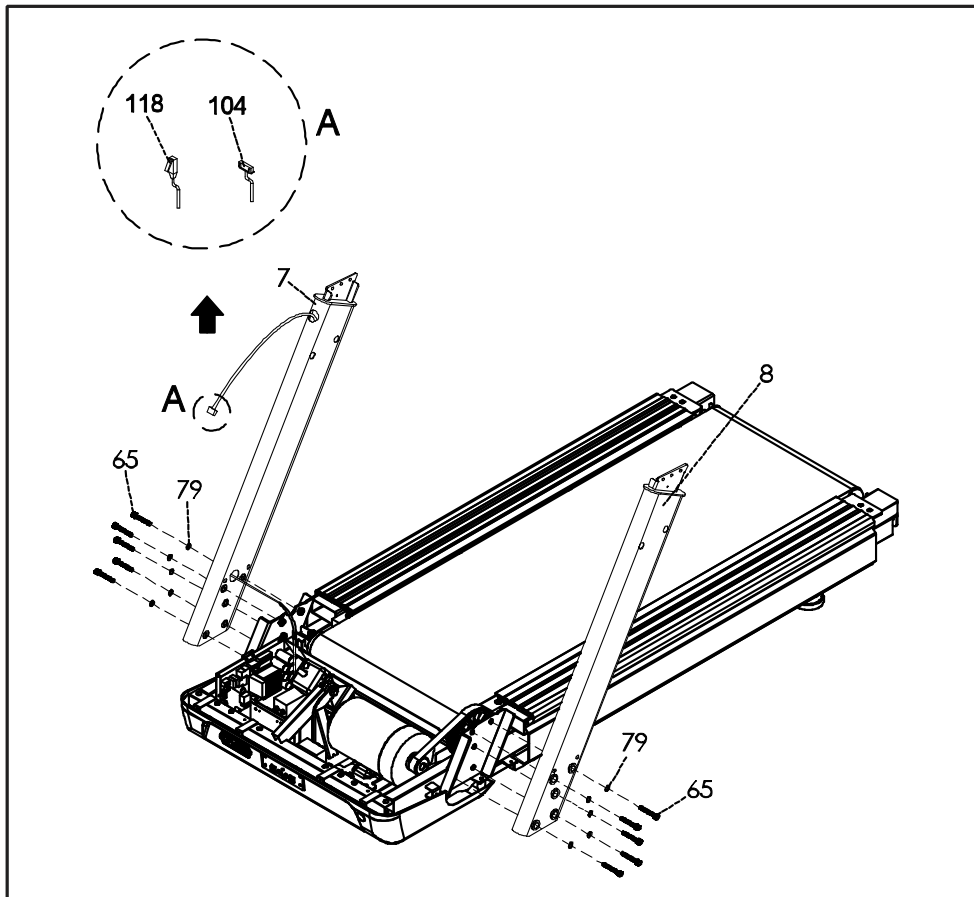
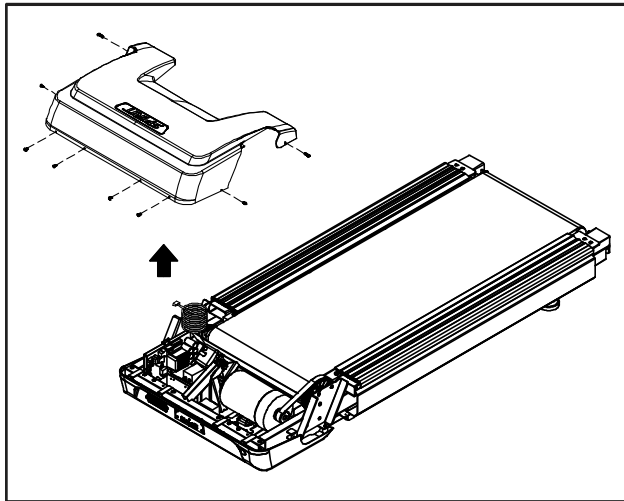

STEP 1

1. Loosen the 8 screws holding the MOTOR COVER (37) in place and remove the cover.
2. Uncoil wiring harness and run wires through the RIGHT UPRIGHT (7).
3. Use 5 BOLTS (65) and 5 LOCK WASHERS (79) to attach the RIGHT UPRIGHT (7) to the MAIN FRAME (1). Do not pinch wires. Do not tighten before putting the console on.
4. Use 5 BOLTS (65) and 5 LOCK WASHERS (79) to attach the LEFT UPRIGHT (8) to the MAIN FRAME (1). Do not tighten before putting the console on.

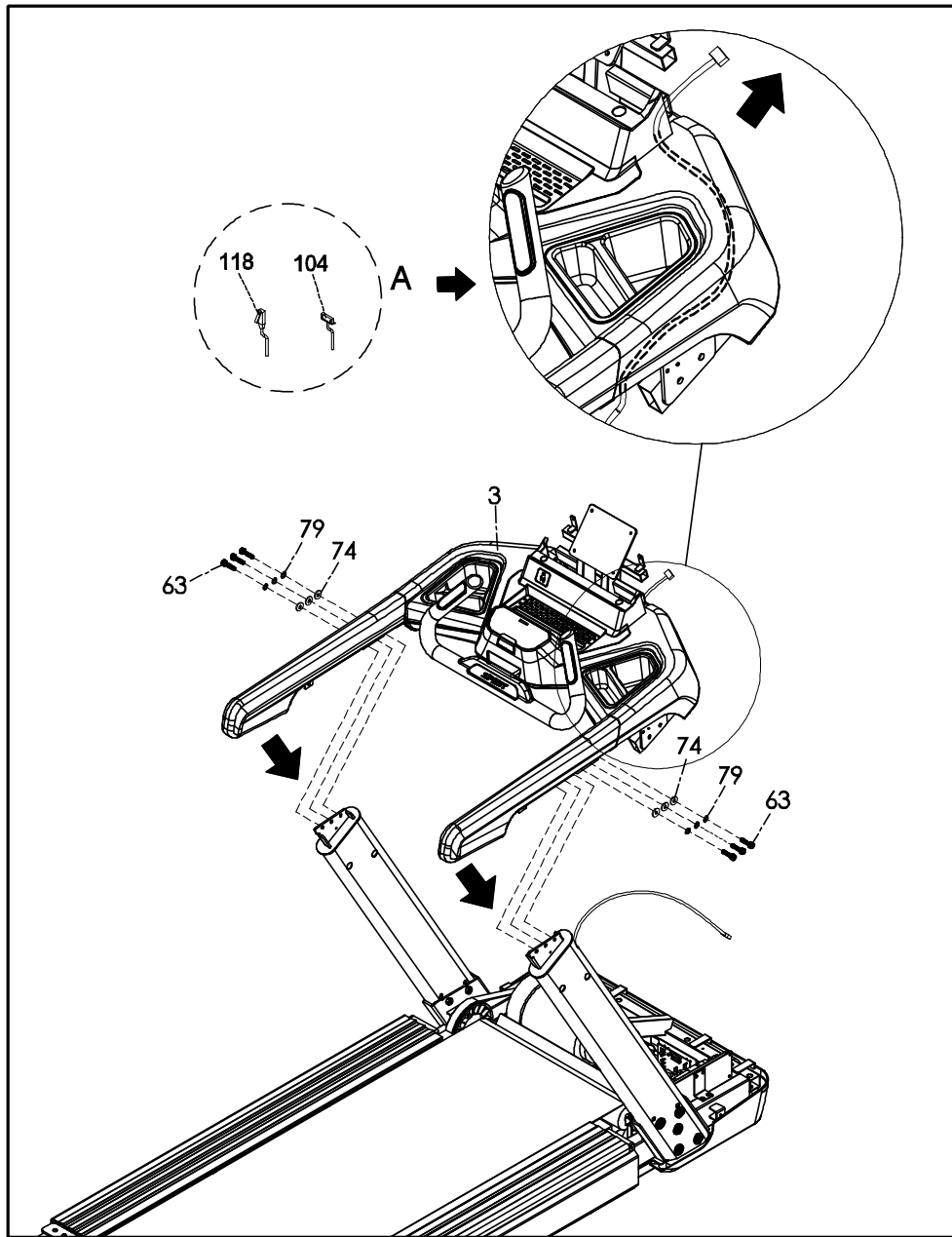

STEP 2

1. Install MAIN PANEL (3) onto the uprights using 6 BOLTS (63), 6 LOCK WASHERS (79) and 6 FLAT WASHERS (74).
2. Run the wiring harness through the MAIN PANEL (3) as shown in the illustration.
3. Tighten all bolts and washers on both uprights (7 and 8) from previous step.

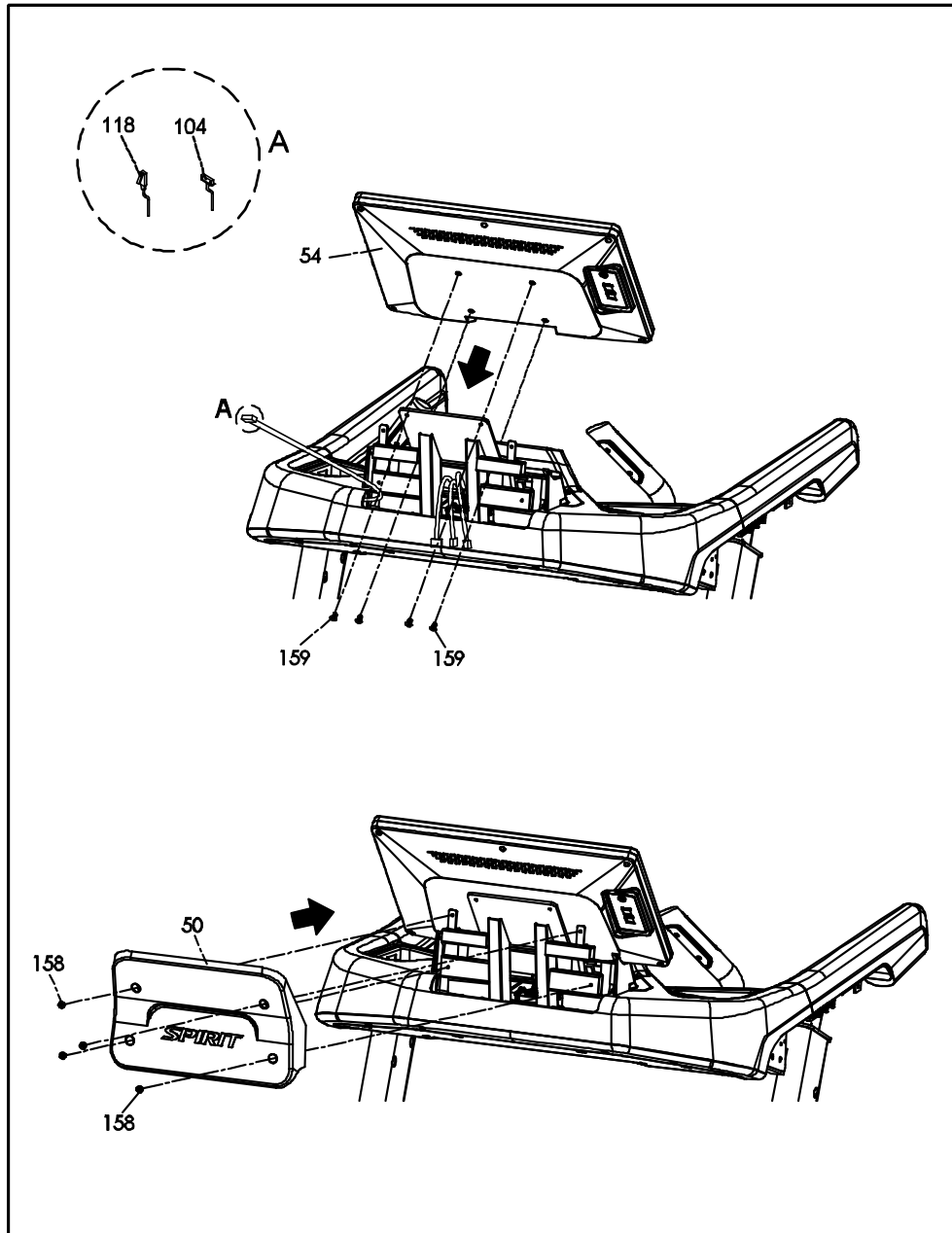

STEP 3

1. Wires should be away from the console mounting bracket.
2. Install the CONSOLE (54) using 4 BOLTS (159).
3. Connect wiring harness to CONSOLE (54).
4. Attach CONSOLE BRACKET COVER (50) to MAIN PANEL using 4 BOLTS (158).

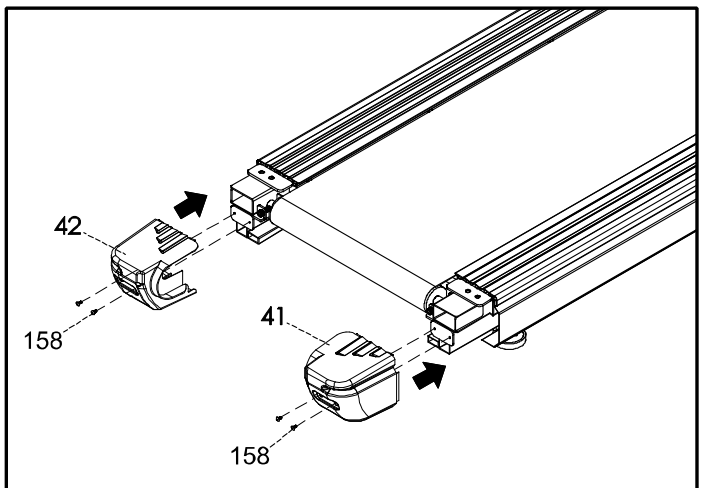
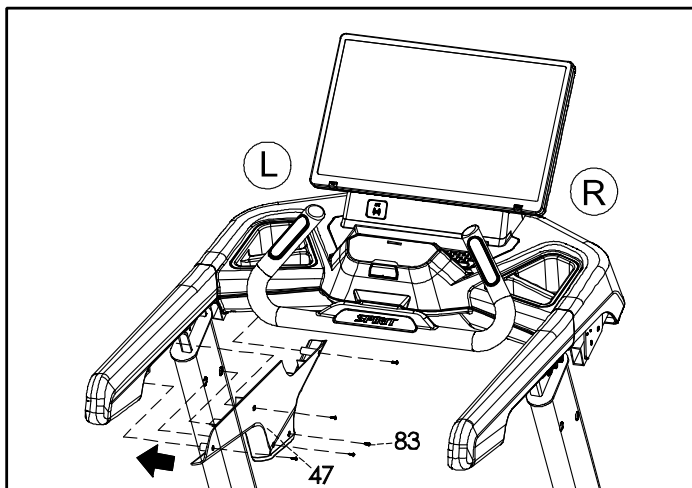
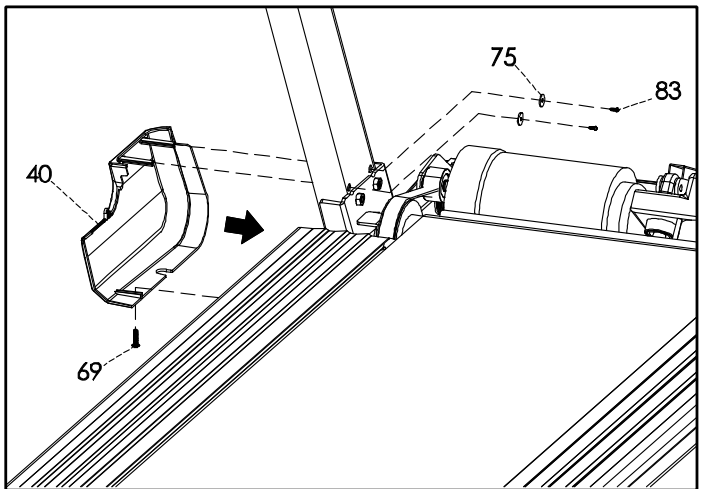
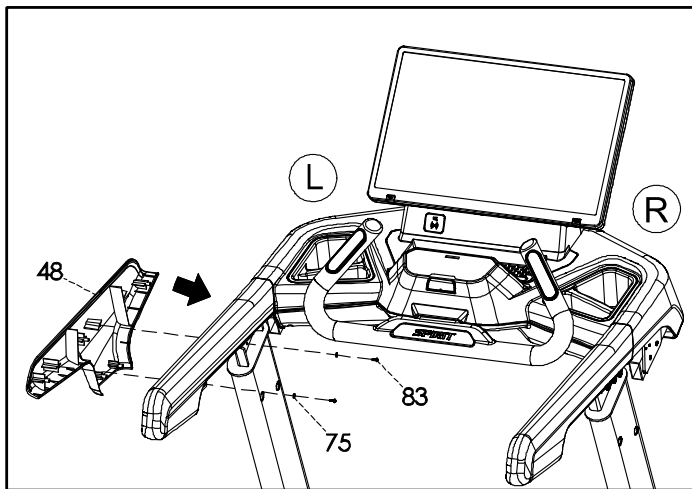

STEP 4

1. Attach LEFT OUTER HANDRAIL COVER (48) to MAIN PANEL using 2 SCREWS (83) and 2 FLAT WASHERS (75).
2. Attach LEFT INNER HANDRAIL COVER (47) to MAIN PANEL using 5 SCREWS (83).
3. Attach LEFT LOWER UPRIGHT COVER (40) to MAIN FRAME (1) using 2 SCREWS (83), 2 FLAT WASHERS (75), and 1 long SCREW (69).
4. Attach LEFT END CAP (42) to MAIN FRAME (1) using 2 SCREWS (158).
5. Repeat to install right side covers (45, 46, 39, 41).
6. Reinstall the MOTOR COVER (37) using the bolts removed in Step 1.

CONSOLE OPERATION



POWER

Power the treadmill on by plugging it into an appropriate wall outlet, then turn on the power switch located at the front of the treadmill below the motor hood. Ensure that the safety key is installed, as the treadmill will not power on without it.

When the power switch is turned on the treadmill console will take around 10 seconds to power on. The console will then enter idle mode, which is the starting point for operation.

C-SAFE FEATURE

Your console is equipped with a C-SAFE feature. The Power (POWER) port can be used for powering a remote controlled audio-visual system by connecting a cable from the remote to the Power port at the back of the console. The Communication port (COMM) can be used to interact with fitness software applications.

Organization Account

Setting up a club organization account will let facility management or other personnel responsible for equipment management, to add cardio equipment to the organization account and then finally allow users to link their Spirit+ Club App accounts, to track their workout history and receive updates from the gym administration.

To set up an organization account, go to Apple App Store or Google Play to download the Spirit+ Connect app. Register on the mobile

app and assign the machine to this account: press Add button on the Equipment page of the app and scan the QR on the machine. Once the unit is assigned, the system will analyze its usage and keep track of all occurring errors.

Use similar method to help customers sign in to the system. First, new gym members must install the Spirit+ Club app on their smartphones and create an account. Use Spirit+ Connect app to give them access: press Add button on the Members page and scan the QR code on their Spirit+ Club app; or present the club's QR code for them to scan.

HOW TO CONNECT WITH THE BLUETOOTH:

After powering on, the device automatically activates the Bluetooth functionality, remaining ready to connect and allowing simultaneous pairing with both the app and the Bluetooth chest. When Will Bluetooth Disconnect from the App or blue tooth chest ?

1. When the user returns to idle mode, if no signal connection is detected within 3 minutes of standby, both the app and heart rate monitor will automatically disconnect.
2. When the user presses pause, if no signal connection is detected within 3 minutes of standby, both the app and heart rate monitor will automatically disconnect.
3. When the user pause a workout but does not return to idle mode, if no signal connection is detected within 3 minutes of standby, both the app and heart rate monitor will automatically disconnect.

QUICK START

Press any key to wake display up if not already on.

- Press any key to wake display up if not already on.
- Press the Start key to begin belt movement at 0.5 mph / 0.8 kph then adjust to the desired speed using the Speed +/- keys, or by typing the desired speed on the numeric keypad. Once setting desired is selected press Enter.
- To stop the treadmill press and release Stop key.

PAUSE/STOP/RESET

When the treadmill is running the pause feature may be utilized by pressing the red Stop key once. This will slowly decelerate the treadmill to a stop. The incline will go to zero percent. The Time, Distance and Calorie readings will hold while the unit is in the pause mode. After 5 minutes the display will reset and return to the start-up screen.

- To resume your exercise when in Pause mode, press the Start key. The speed and incline will return to their previous settings.
- Pressing the Stop key twice will end the program and a workout summary will be displayed. If the Stop button is pressed a third time, the console will return to the idle mode (start-up screen).
- If the Stop button is held down for more than three seconds the console will reset.
- When you are setting data, such as age and time, for a program pressing the Stop key will allow you to go back one step for each key press.

INCLINE

Incline may be adjusted any time after the belt starts moving.

- Press and hold the adjustment Incline +/- keys to achieve desired level of incline.
- The display will indicate incline numbers as percent of grade (the same as grade of a road) as adjustments are made.

DOT MATRIX CENTER DISPLAY

Ten rows of dots indicate each level of a workout in manual mode. The dots are only to show an approximate level (speed/incline) of effort. They do not necessarily indicate a specific value, only an approximate percent to compare levels of intensity. In Manual Operation the Speed / Incline dot matrix window will build a profile "picture" as values are changed during a workout. There are twenty-four columns, indicating time. The 24 columns are divided into 1/24th of the total time of the program. When the time is counting up from zero (as in quick start) each column represents 1 minute.

0.4 KM (1/4 MILE) TRACK

The 1/4-mile track (0.4 km) and lap counter are located to the left of the dot matrix window. The flashing dot indicates your progress. In the center of the track there is a lap counter for reference.

HEART RATE FEATURE

The Pulse (Heart Rate) window will display your current heart rate in beats per minute during the workout.

You must use both left and right stainless steel sensors to pick up your pulse. Pulse values are displayed any time the computer is receiving a Grip Pulse signal. You may use the Grip Pulse feature while in Heart Rate Control.

HEART RATE BAR GRAPH

Displays a graphical representation of your heart rate as a percentage of your estimated maximum heart rate. When you enter your age during programming, the console will calculate your maximum heart rate then light up the graph to show the percent of estimated maximum heart rate you are currently achieving.

MESSAGE WINDOW DISPLAY

Displays messages that help guide you through the programming process. During a program the message window displays your workout data.

PROGRAMMABLE FEATURES

The Spirit Fitness offers a variety of exercise program options to choose from: Manual, Five Preset Programs (Hill, Fat Burn, Cardio, Strength, Interval), 5K/10K Run, Heart Rate Control, High Intensity Interval Training (HIIT), and Nine Fitness Testing Protocols: Gerkin, WFI, Army (pft), Navy (prt), Air Force (prt), Marines (pft), Law Enforcement (peb), U.S. Coast Guard and U.K. Chester Fireman (Performance & Prediction protocols).

To Select and Start a Preset Program

1. Select a preset program key then press Enter to begin customizing the program with your personal data, or just press the Start key to begin the program with the default settings.
2. After selecting a program and pressing enter to set your personal data, the Message window will prompt you through the settings starting with time. The default value of 20 minutes will be displayed and you may press Enter to accept or change it using the keypad or Up / Down keys and just press enter to move to the next step
3. The Message Window will now be blinking a value indicating your Age. Entering the correct age will affect the Heart Rate Bar Graph accuracy and also needed for the HR programs. Use the keypad or Up / Down keys to adjust, and then press enter.
4. The Message Window will now be blinking a value indicating your Bodyweight. Entering your correct bodyweight affects the Calorie readout accuracy. Use the keypad or Up / Down keys to adjust, and then press Enter.
5. The Message Window will now be blinking, showing the preset top speed of the selected program. Use the keypad or Up / Down keys to adjust and then press Enter. Each program has various speed changes throughout; this allows you to limit the highest speed the program will attain during your workout.
6. Now press the Start key to begin your workout, or the Stop button to return to the previous screen.
7. There will be a 3-minute warm-up to begin. You can press the Start button to bypass this and go straight to the workout. During the warm-up the clock will count down from three minutes.

PRESET PROGRAMS SPEED/INCLINE SETTINGS

The preset program Speed and Incline levels are shown in the chart below. The Speed numbers shown in the chart indicate a percentage of the top speed of the program. For instance, the first Speed

setting for P1 (Program 1, Hill) shows the number 20. This means that this segment of the program will have a speed that is 20% of the top speed for the program (The user sets the top speed in the procedure above). If the user sets the top speed to 15 mph / 24 kph, then the first segment will be 3 mph / 4.8 kph. You will notice that segment 12 shows 100 which means, the speed will be set to 100% of 15 mph / 24 kph or simply 15 mph / 24 kph.

P1= HILL; P2= FAT BURN; P3= CARDIO; P4= STRENGTH; P5= INTERVAL

Prog	SEG	Warm up	1	2	3	4	5	6	7	8	9	10	11	12	13	14	15	16	17	18	19	20	21	22	23	24	25	26	27	28	29	30	31	32	Cool down			
Hill	Speed	20	30	40	50	50	60	60	60	70	70	70	80	80	80	80	80	100	100	70	80	80	80	70	70	80	80	70	70	60	60	60	50	50	40	30	20	
	Incline	0	0	0	0	0	0	1	1	1	2	2	2	2	3	3	3	3	4	4	4	4	3	3	3	3	2	2	2	2	2	1	1	1	0	0	0	0
Fat burn	Speed	20	30	40	50	60	60	70	80	100	100	100	100	100	100	100	100	100	100	100	100	100	100	100	100	100	100	100	100	80	70	60	60	50	40	30	20	
	Incline	0	0	0	0	0	0	2	2	2	2	2	2	2	2	2	2	2	2	2	2	2	2	2	2	2	2	2	2	2	2	2	2	0	0	0	0	0
Cardio	Speed	20	30	40	50	60	60	70	70	70	80	70	70	80	80	60	70	80	80	70	100	80	80	60	70	80	80	70	70	100	70	80	60	60	50	40	30	20
	Incline	0	0	0	0	0	0	0	3	4	1	1	1	1	4	1	1	1	1	4	1	1	1	4	1	1	1	1	1	3	0	0	0	0	0	0	0	0
Strength	Speed	20	30	40	50	60	60	70	70	80	80	90	90	100	100	100	100	100	100	100	100	100	100	100	100	100	100	100	100	100	100	80	60	50	40	30	20	
	Incline	0	0	0	0	0	0	3	3	3	3	3	3	3	4	4	4	4	4	4	4	4	4	4	4	4	4	3	3	3	3	3	3	0	0	0	0	0
Interval	Speed	20	30	40	50	60	60	70	80	100	60	70	100	60	70	80	100	60	70	100	60	70	100	60	70	100	60	70	80	70	60	60	50	40	30	20		
	Incline	0	0	0	0	0	1	4	4	1	1	4	4	1	1	4	4	1	1	4	4	1	1	4	4	1	1	4	4	1	1	4	4	1	0	0	0	0

HIIT PROGRAM

The HIIT, or High Intensity Interval Training, program takes advantage of the latest trend in fitness. During the program you will perform short bursts of high intensity sprinting followed by short rest periods. HIIT is a fully customizable interval training program. You can enter the number of intervals, time of each interval Sprint and Rest periods and the work intensity of the levels.

1. Press the HIIT key then Enter. The Message Window will ask you to enter your Age. You may enter your Age, using the Up and Down keys or the numeric key pad, then press the Enter key to accept the new number and proceed on to the next screen.
2. You are now asked to enter your Weight. You may adjust the Weight number using the Up and Down keys or the numeric key pad then press Enter to continue.
3. Next you are asked for the number of intervals you want to do. The default is 10 and the range available is 3 to 15. One interval equals 1 Sprint and 1 Rest segment.
4. Next is entering the Interval time. The Message Window shows: Sprint :30 | Rest :30. The Sprint time will be blinking. You may use the + - keys to adjust the Sprint time from 30 to 60 seconds then press Enter. The time for the Rest period will blink and you can adjust the time using the + - keys and press Enter. The Message Window will display the total program time.
5. The Message Window now displays SPRINT SPD 6.0 MPH / 9.6 kph. Use the Up and Down keys to adjust the sprint speed you desire and press enter.
6. The Message Window now displays REST SPEED 3.0 MPH / 4.8 kph. Use the Up and Down keys to adjust the rest speed you desire and press enter.
7. You may now press Start to begin the HIIT program. The program starts with a 3-minute warm-up period with the speed set to 50% of the sprint speed selected previously. You can manually adjust the speed during warm-up if you wish.

5K RUN

This program automatically sets a 5K distance as your goal. The track display will show one loop that is the equivalent of 5 kilometers and the Distance window will also show 5K to start. When the program begins the Distance will count down; once it reaches zero the program ends.

**Please note that the Speed readout is in MPH if the console is not set to Metric.*

FITNESS TEST

When the Fit Test key is pressed the DM displays: GERKIN. This is the first of 9 different tests available: Gerkin, WFI, Army (pft), Navy (prt), Air Force (prt), Marines (pft), Law Enforcement (peb), U.S. Coast Guard, and U.K. Chester Fireman (Performance & Prediction protocols). The initial test is GERKIN; to select a different test press the Fitness Test key again and the next test will be shown. Continue to press the Fitness Test key until the test you want is shown in the message window. To select your desired fitness test, press Enter.

FIT TEST OPERATION

1. For each program the Message Window will prompt you to enter your personal data such as Age, Weight, Height, Gender. You may adjust the settings using the keypad or Up and Down keys then press the Enter key to accept the new number and proceed on to the next screen.
2. After all required data is entered you may now press Start to begin the test.

ARMY

A timed 2 mile / 3.2 kph run. You control the speed manually. Maximum time allowed to pass the test.

Age	Male	Female
17-21	16:36	19:42
22-26	17:30	20:36
27-31	17:54	21:42
32-36	18:48	23:06
37-41	19:30	24:06

For more detailed information, visit: <http://bit.ly/SF-Army>

AIR FORCE

A timed 1.5 mile / 2.4kph run. You control the speed manually. Maximum time allowed to pass the test:

Age	Male	Female
<30	13:36	16:22
30-39	14:00	16:57
40-49	14:52	18:14
50-59	16:22	19:43
60+	18:14	22:28

For more detailed information, visit: <http://bit.ly/SF-AirForce>

NAVY

A timed 1.5 mile/ 2.4 kph run. You control the speed manually. Maximum time allowed to pass the test:

Age	Male	Female
19	12:30	15:00
20-24	13:30	15:30
25-29	14:00	16:08
30-34	14:30	16:45
35-39	15:00	17:00
40-44	15:30	17:15

Age	Male	Female
45-49	16:08	17:23
50-54	16:45	17:30
55-59	17:09	18:34
60-64	18:52	19:43
65+	20:35	20:52

For more detailed information, visit: <http://bit.ly/SF-Navy>

MARINES

A timed 3 mile/ 4.8 kph run. You control the speed manually. Maximum time allowed to pass the test:

Age	Male	Female
17-26	28:00	31:00
27-39	29:00	32:00
40-45	30:00	33:00
46+	33:00	36:00

For more detailed information, visit: <http://bit.ly/SF-Marines>

COAST GUARD

A timed 1.5 mile/ 2.4kph run. You control the speed manually. Maximum time allowed to pass the test:

Male	20-29 Yrs. Old	30-39 Yrs. Old	40-49 Yrs. Old	50-59 Yrs. Old	60+ Yrs. Old
Superior	<9:17	<9:33	<9:51	<10:37	<11:26
Excellent	9:18-10:09	9:34-10:46	9:52-11:15	10:28-12:08	11:27-13:23
Good	10:10-11:29	10:47-11:54	11:16-12:24	12:09-13:35	13:24-15:04
Fair	11:30-12:38	11:55-12:58	12:25-13:50	13:36-15:06	15:05-16:46
Poor	12:39-14:00	12:59-14:34	13:51-15:24	15:07-16:58	16:47-19:10
Very Poor	>14:00	>14:34	>15:24	>16:58	>19:10
Failure	>12:51	>13:36	>14:29	>15:26	>16:40
Female	20-29 Yrs. Old	30-39 Yrs. Old	40-49 Yrs. Old	50-59 Yrs. Old	60+ Yrs. Old
Superior	<10:28	<11:00	<11:33	<12:53	<14:05
Excellent	10:29-11:58	11:01-12:24	11:34-13:23	12:54-14:34	14:06-16:33
Good	11:59-13:24	12:25-14:08	13:24-14:53	14:35-16:35	16:34-18:27
Fair	13:25-14:50	14:09-15:43	14:54-16:31	16:36-18:18	18:28-20:16
Poor	14:51-16:46	15:44-17:38	16:32-18:37	18:19-20:44	20:17-22:52
Very Poor	>16:46	>17:38	>18:37	>20:44	>22:52
Failure	>15:26	>15:57	>16:58	>17:55	>18:44

LAW ENFORCEMENT (PEB)

A timed 1.5 mile / 2.4kph run. You control the speed manually. Maximum time allowed to pass the test:

For more detailed information, visit: <https://www.fletc.gov/peb-scores-age-and-gender>

GERKIN

The Gerkin protocol, also known as the fireman's protocol, is a sub-max Vo2 (volume of oxygen) test. The test will increase speed and elevation alternately until you reach 85% of your Max heart rate. The time it takes for you to reach 85% determines the test score (VO2max) as shown in the chart below.

Stage	Time	Speed	Grade	VO2 Max
1	0 to 1:00	7.2KPH	0%	31.15
2.1	1:00	7.2KPH	2%	32.55
2.2	1:30	7.2KPH	2%	33.6
2.3	1:45	7.2KPH	2%	34.65
2.4	2:00	8.0KPH	2%	35.35
3.1	2:15	8.0KPH	2%	37.45
3.2	2:30	8.0KPH	2%	39.55
3.3	2:45	8.0KPH	2%	41.3
3.4	3:00	8.0KPH	4%	43.4
4.1	3:15	8.0KPH	4%	44.1
4.2	3:30	8.0KPH	4%	45.15
4.3	3:45	8.0KPH	4%	46.2
4.4	4:00	8.8KPH	4%	46.5
5.1	4:15	8.8KPH	4%	48.6
5.2	4:30	8.8KPH	4%	50
5.3	4:45	8.8KPH	4%	51.4
5.4	5:00	8.8KPH	6%	52.8
6.1	5:15	8.8KPH	6%	53.9
6.2	5:30	8.8KPH	6%	54.9
6.3	5:45	8.8KPH	6%	56
6.4	6:00	9.6KPH	6%	57
7.1	6:15	9.6KPH	6%	57.7
7.2	6:30	9.6KPH	6%	58.8
7.3	6:45	9.6KPH	6%	60.2
7.4	7:00	9.6KPH	8%	61.2
8.1	7:15	9.6KPH	8%	62.3
8.2	7:30	9.6KPH	8%	63.3
8.3	7:45	9.6KPH	8%	64
8.4	8:00	10.4KPH	8%	65
9.1	8:15	10.4KPH	8%	66.5
9.2	8:30	10.4KPH	8%	68.2
9.3	8:45	10.4KPH	8%	69
9.4	9:00	10.4KPH	10%	70.7
10.1	9:15	10.4KPH	10%	72.1
10.2	9:30	10.4KPH	10%	73.1
10.3	9:45	10.4KPH	10%	73.8
10.4	10:00	11.2KPH	10%	74.9
11.1	10:15	11.2KPH	10%	76.3
11.2	10:30	11.2KPH	10%	77.7
11.3	10:45	11.2KPH	10%	79.1
11.4	11:00	11.2KPH	10%	80

Stage	Time	Speed	Grade	VO2 Max
1	0 to 1:00	4.5MPH	0%	31.15
2.1	1:00	4.5MPH	2%	32.55
2.2	1:30	4.5MPH	2%	33.6
2.3	1:45	4.5MPH	2%	34.65
2.4	2:00	5.0MPH	2%	35.35
3.1	2:15	5.0MPH	2%	37.45
3.2	2:30	5.0MPH	2%	39.55
3.3	2:45	5.0MPH	2%	41.3
3.4	3:00	5.0MPH	4%	43.4
4.1	3:15	5.0MPH	4%	44.1
4.2	3:30	5.0MPH	4%	45.15
4.3	3:45	5.0MPH	4%	46.2
4.4	4:00	5.5MPH	4%	46.5
5.1	4:15	5.5MPH	4%	48.6
5.2	4:30	5.5MPH	4%	50
5.3	4:45	5.5MPH	4%	51.4
5.4	5:00	5.5MPH	6%	52.8
6.1	5:15	5.5MPH	6%	53.9
6.2	5:30	5.5MPH	6%	54.9
6.3	5:45	5.5MPH	6%	56
6.4	6:00	6.0MPH	6%	57
7.1	6:15	6.0MPH	6%	57.7
7.2	6:30	6.0MPH	6%	58.8
7.3	6:45	6.0MPH	6%	60.2
7.4	7:00	6.0MPH	8%	61.2
8.1	7:15	6.0MPH	8%	62.3
8.2	7:30	6.0MPH	8%	63.3
8.3	7:45	6.0MPH	8%	64
8.4	8:00	6.5MPH	8%	65
9.1	8:15	6.5MPH	8%	66.5
9.2	8:30	6.5MPH	8%	68.2
9.3	8:45	6.5MPH	8%	69
9.4	9:00	6.5MPH	10%	70.7
10.1	9:15	6.5MPH	10%	72.1
10.2	9:30	6.5MPH	10%	73.1
10.3	9:45	6.5MPH	10%	73.8
10.4	10:00	7.0MPH	10%	74.9
11.1	10:15	7.0MPH	10%	76.3
11.2	10:30	7.0MPH	10%	77.7
11.3	10:45	7.0MPH	10%	79.1
11.4	11:00	7.0MPH	10%	80

WFI

The WFI test is a modified Gerkin protocol. The actual test is the same as the Gerkin chart above, but the score is calculated differently.

Before the Gerkin/ WFI Test:

1. Make sure you are in good health; check with your physician before performing any exercise if you are over the age of 35 or persons with pre-existing health conditions.
2. Make sure you have warmed up and stretched before taking the test.
3. Do not take in caffeine before the test.
4. Hold the hand grips gently, do not tense up.

During the Test:

1. The console must be receiving a steady heart rate for the test to begin. You may use the hand pulse sensors or wear a heart rate chest strap transmitter.
2. The test will start with a 3-minute warm-up at 3 MPH / 4.8 kph before the actual test begins.
3. The data shown during the test is:
 - a. Time indicates total elapsed time
 - b. Incline in percent grade
 - c. Distance in Miles or Kilometers depending on preset parameter.
 - d. Speed in MPH or KPH depending on preset parameter.
 - e. Target Heart Rate and Actual Heart Rate are shown in the Message Window.

After the Test

1. Cool down for about one to three minutes.
2. Take note of your score because the console will automatically return to the start-up mode after a few minutes.

WHAT YOUR SCORE MEANS

VO2max Chart for males and very fit females

	18-25 years old	26-35 years old	36-45 years old	46-55 years old	56-65 years old	65+ years old
excellent	>60	>56	>51	>45	>41	>37
good	52-60	49-56	43-51	39-45	36-41	33-37
above average	47-51	43-48	39-42	35-38	32-35	29-32
average	42-46	40-42	35-38	32-35	30-31	26-28
below average	37-41	35-39	31-34	29-31	26-29	22-25
poor	30-36	30-34	26-30	25-28	22-25	20-21
very poor	<30	<30	<26	<25	<22	<20

VO2max Chart for females and de-conditioned males

	18-25 years old	26-35 years old	36-45 years old	46-55 years old	56-65 years old	65+ years old
excellent	56	52	45	40	37	32
good	47-56	45-52	38-45	34-40	32-37	28-32
above average	42-46	39-44	34-37	31-33	28-31	25-27
average	38-41	35-38	31-33	28-30	25-27	22-24
below average	33-37	31-34	27-30	25-27	22-24	19-22
poor	28-32	26-30	22-26	20-24	18-21	17-18
very poor	<28	<26	<22	<20	<18	<17

CHESTER TREADMILL TEST

This test has two modes: CTT Performance and CTT Prediction (of Aerobic Capacity).

CTT PERFORMANCE

CTT Performance is a 12-minute graded, treadmill walk test with a fixed speed of 6.2km/hr designed to assess whether or not the subject can achieve the minimum recommended standard for aerobic capacity, namely 42mlsO₂/kg/min.

Procedures:

1. Check there are no medical contraindications to performing exhaustive exercise
2. Subject walks at 6.2km/hr at 0% for 2 mins
3. Every 2 mins increase gradient by 3%
4. Test is completed after 12 mins
5. Test should be stopped if subject is showing overt signs of distress and exhaustion or RPE=18+

CTT Prediction

CTT Prediction is a submaximal test designed to predict aerobic capacity

1. Same walk protocol as CTT Performance but wearing HR monitor
2. Test is stopped when the subject reaches 80%HRMax or RPE=14
3. A VO₂ score is given at the end of the test

HEART RATE PROGRAM

Heart Rate Control (HRC) uses your treadmill's incline system to control your heart rate via information from pulse grips or wireless chest strap. Increases and decreases in elevation affect heart rate much more efficiently than changes in speed alone. The HRC program automatically changes elevation gradually to achieve the programmed target heart rate.

Selecting a Heart Rate Control Program:

You have the option, during the setup mode, to choose either the Weight Control (HR 1) program or the Cardiovascular (HR 2) program. The Weight Control program will attempt to maintain your heart rate at 65% of your Maximum Heart Rate. The Cardiovascular program will attempt to maintain your heart rate at 80% of your Maximum Heart Rate. Your Maximum Heart Rate is based upon a formula that subtracts your age from a constant of 220. Your HR setting is automatically calculated during the setup mode when you enter your age.

Heart Rate Control Programming:

1. Press HR button to enter heart rate program.
2. Now the window will show PRESS ENTER TO MODIFY OR START TO BEGIN WORKOUT. You can either press the Enter button for settings or press the Start button to execute the program.
3. When the Enter button is pressed, the Message Window shows PRESS 1 OR 2 TO SELECT THEN PRESS ENTER.
At the same time, the dot matrix window is showing "1" and you can press numeric keypad 1 or 2 and then the Enter button.
4. Now Message Window is showing ADJUST TIME THEN PRESS ENTER with Time Window blinking. Use Up/Down keys or numeric keys to adjust. After setting time, press the Enter button again.
5. Now Message Window is showing ADJUST AGE THEN PRESS ENTER with Incline Window blinking. Use Up/Down/ Fast/Slow keys or numeric keys to adjust. Adjusting age will change THR value (as the THR formula described previously). After age is set, press the Enter button again.

6. Now Message Window is showing ADJUST BODY WEIGHT THEN PRESS ENTER with Incline Window blinking. Use Up/Down keys or numeric keys to adjust. After the weight is set, press Enter button again.
7. Now Message Window is showing ADJUST HEART RATE THEN PRESS ENTER with Speed Window blinking. Use Up/Down keys or numeric keys to adjust. After the target heart rate value is set, press the Enter button again.
8. The Message Window is then showing PRESS START TO BEGIN WORKOUT OR ENTER TO MODIFY. Press Start button to begin the workout or Stop button to return to the previous screen.

Note: When the Message Window is showing CHECK PULSE, there is no pulse signal received and the program cannot be performed. Please check and make sure that heart rate strap functions normally.

SAFETY TETHER CORD

A safety tether cord is provided with this unit. It is a simple magnetic design that should be used at all times. It is for your safety should you fall or move too far back on the tread-belt.

Pulling this safety tether cord will stop tread-belt movement.

To Use:

1. Place the magnet into position on the console control head. Your treadmill will not start and operate without this.
2. Fasten the plastic clip onto your clothing securely to assure good holding power. **Note:** The magnet has strong enough power to minimize accidental, unexpected stopping. The clip should be attached securely to make certain it does not come off. Be familiar with its function and limitations. The treadmill will stop, depending on speed, with a one to two step coast anytime the magnet is pulled off the console. Use the red Stop / Pause switch in normal operation.
3. If for any reason you feel unstable on the moving belt, immediately step off of the belt and onto the step rails while holding the handrails for support. You can then step off the treadmill safely.

TARGET HEART RATE

The old motto, “no pain, no gain”, is a myth that has been overpowered by the benefits of exercising comfortably. A great deal of this success has been promoted by the use of heart rate monitors. With the proper use of a heart rate monitor, many people find that their usual choice of exercise intensity was either too high or too low and exercise is much more enjoyable by maintaining their heart rate in the desired benefit range.

To determine the benefit range in which you wish to train, you must first determine your Maximum Heart Rate. This can be accomplished by using the following formula: 220 minus your age. This will give you the Maximum heart rate (MHR) for someone of your age. To determine the effective heart rate range for specific goals you simply calculate a percentage your MHR. Your Heart rate training zone is 50% to 90% of your maximum heart rate. 65% of your MHR is the zone that burns fat while 85% is for strengthening the cardio vascular system. This 65% to 85% is the zone to stay in for maximum benefit.

For someone who is 40 years old their target heart rate zone is calculated:

$$\begin{aligned} 220 - 40 &= 180 \text{ (maximum heart rate)} \\ 180 \times .65 &= 117 \text{ beats per minute (65\% of maximum)} \\ 180 \times .85 &= 153 \text{ beats per minute (85\% of maximum)} \end{aligned}$$

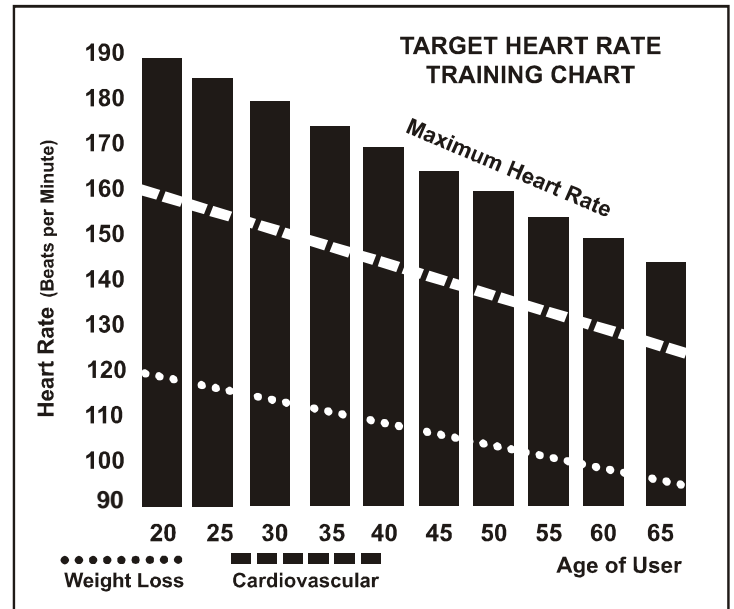

So, for a 40 year old the training zone would be 117 to 153 beats per minute.

If you enter your age during programming the console will perform this calculation automatically. Entering your age is used for the Heart Rate control programs. After calculating your Maximum Heart Rate you can decide upon which goal you would like to pursue.

The two most popular reasons for, or goals, of exercise are cardiovascular fitness (training for the heart and lungs) and weight control. The black columns on the chart above represent the Maximum Heart Rate for a person whose age is listed at the bottom of each column. The training heart rate, for either cardiovascular fitness or weight loss, is represented by two different lines that cut diagonally through the chart. A definition of the lines' goal is in the bottom left-hand corner of the chart. If your goal is cardiovascular fitness or if it is weight loss, it can be achieved by training at 85% or 65%, respectively, of your Maximum Heart Rate on a schedule approved by your physician. Consult your physician before participating in any exercise program.

With all Heart Rate Control treadmill you may use the heart rate monitor feature without using the Heart Rate Control program. However, when using the heart rate monitor feature in conjunction with the Heart Rate programs, the machine will automatically adjust speed or incline to maintain the desired heart rate.

”WARNING” Heart rate monitoring system may be inaccurate. Over exercise may result in injury or death. If you feel faint stop exercising immediately.

RATE OF PERCEIVED EXERTION

Heart rate is important but listening to your body also has a lot of advantages. There are more variables involved in how hard you should workout than just heart rate. Your stress level, physical health, emotional health, temperature, humidity, the time of day, the last time you ate and what you ate, all contribute to the intensity at which you should workout. If you listen to your body, it will tell you all of these things.

The rate of perceived exertion (RPE), also known as the Borg scale, was developed by Swedish physiologist G.A.V. Borg. This scale rates exercise intensity from 6 to 20 depending upon how you feel or the perception of your effort.

The scale is as follows:

Rating Perception of Effort

- 6 Minimal
- 7 Very, very light
- 8 Very, very light +
- 9 Very light
- 10 Very light +
- 11 Fairly light
- 12 Comfortable
- 13 Somewhat hard
- 14 Somewhat hard +
- 15 Hard
- 16 Hard +
- 17 Very hard
- 18 Very hard +
- 19 Very, very hard
- 20 Maximal

You can get an approximate heart rate level for each rating by simply adding a zero to each rating. For example, a rating of 12 will result in an approximate heart rate of 120 beats per minute. Your RPE will vary depending on the factors discussed earlier. That is the major benefit of this type of training. If your body is strong and rested, you will feel strong, and your pace will feel easier. When your body is in this condition, you are able to train harder and the RPE will support this. If you are feeling tired and sluggish, it is because your body needs a break. In this condition, your pace will feel harder. Again, this will show up in your RPE and you will train at the proper level for that day.

USING A HEART RATE TRANSMITTER (OPTIONAL)

How to wear your wireless chest strap transmitter:

1. Attach the transmitter to the elastic strap using the locking parts.
2. Adjust the strap as tightly as possible as long as the strap is not too tight to remain comfortable.
3. Position the transmitter with the logo centered in the middle of your body facing away from your chest (some people must position the transmitter slightly left of center). Attach the final end of the elastic strap by inserting the round end and, using the locking parts, secure the transmitter and strap around your chest.
4. Position the transmitter immediately below the pectoral muscles.
5. Sweat is the best conductor to measure very minute heart beat electrical signals. However, plain water can also be used to pre-wet the electrodes (2 ribbed oval areas on the reverse side of the belt and both sides of the transmitter). It's also recommended that you wear the transmitter strap a few minutes before your work out. Some users, because of body chemistry, have a more difficult time in achieving a strong, steady signal at the beginning. After "warming up", this problem lessens. As noted, wearing clothing over the transmitter/strap doesn't affect performance.
6. Your workout must be within range - distance between transmitter/receiver – to achieve a strong steady signal. The length of range may vary somewhat but generally stay close enough to the console to maintain good, strong, reliable readings. Wearing the transmitter immediately against bare skin assures you of proper operation. If you wish, you may wear the transmitter over a shirt. To do so, moisten the areas of the shirt that the electrodes will rest upon.



Note: The transmitter is automatically activated when it detects activity from the user's heart. Additionally, it automatically deactivates when it does not receive any activity. Although the transmitter is water resistant, moisture can have the effect of creating false signals, so you should take precautions to completely dry the transmitter after use to prolong battery life (estimated transmitter battery life is 2500 hours). The replacement battery is Panasonic CR2032.

ERRATIC OPERATION

Caution! Do not use this treadmill for Heart Rate programs unless a steady, solid Actual Heart Rate value is being displayed. High, wild, random numbers being displayed indicate a problem. Areas to look for interference which may cause erratic heart rate:

1. Treadmill is not properly grounded.
2. Microwave ovens, TV's, small appliances, etc.
3. Fluorescent lights.
4. Some household security systems.
5. Some people have problems with the transmitter picking up a signal from their skin. If you have problems try wearing the transmitter upside down. Normally the transmitter will be oriented so the Spirit Fitness logo is right side up.
6. The antenna that picks up your heart rate is very sensitive. If there is an outside noise source, turning the whole machine 90 degrees may de-tune the interference.
7. Another Individual wearing a transmitter within 3' of your machine's console.

If you continue to experience problems, contact your dealer.

GENERAL MAINTENANCE

WARNING: The effect that the safety level of the equipment can be maintained only if it is examined regularly for damage and wear.

The components which are most susceptible to wear: Belt · Idler · roller · Desk · Tread-belt.

Belt and Deck - Your treadmill uses a very high-efficient low-friction bed. Performance is maximized when the bed is kept as clean as possible. Use a soft, damp cloth or paper towel to wipe the edge of the belt and the area between the belt edge and frame. Also reach as far as practical directly under the belt edge. This should be done once a month to extend belt and bed life. Use water only - no cleaners or abrasives. A mild soap and water solution along with a nylon scrub brush will clean the top of the textured belt. **Allow the belt to dry before using.**

The low maintenance (routine monthly cleaning), dual-sided hard wax deck is designed to withstand up to 20,000 kilometers on each side. If the original side of the deck shows significant wear, it needs to be flipped.

Contact your service technician for assistance. Do not apply any type of lubricant or wax to the surface.

Belt Dust - This occurs during normal break-in or until the belt stabilizes. Wiping excess off with a damp cloth will minimize buildup.

General Cleaning - Dirt, dust, and pet hair can block air inlets and accumulate on the running belt. On a monthly basis: vacuum underneath your treadmill to prevent buildup. Once a year, you should remove the motor hood and vacuum out dirt that may accumulate. **UNPLUG POWER CORD BEFORE THIS PERFORMING THIS TASK. Do not** attempt any servicing or adjustments other than those described in this manual. Opening the motor cover must be left to trained service personnel familiar with electro-mechanical equipment and authorized under the laws of the country in question to carry out maintenance and repair work.

BELT ADJUSTMENTS:

Running surface : 56x224cm

Tread-belt Tension Adjustment - Adjustment must be made from the rear roller. The adjustment bolts are located at the end of the step rails in the end caps, as noted in diagram below.

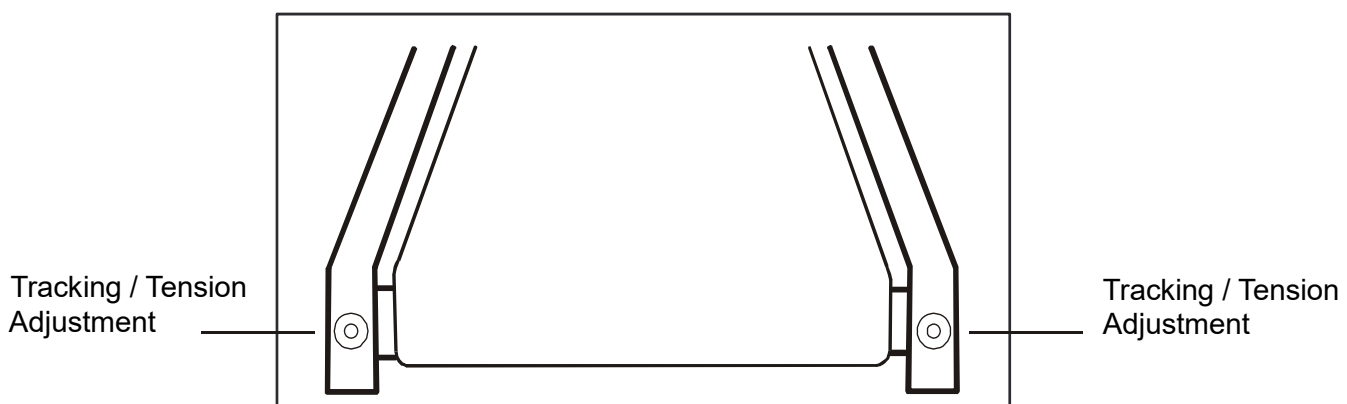

Note: Adjustment is through small hole in the end cap.

Tighten the rear roller bolts only enough to prevent slippage at the front roller. Turn both tread-belt tension adjustment bolts in increments of 1/4 turn each and inspect for proper tension by walking on the belt at a low speed, making sure the belt does not slip. Keep tensioning the bolts until the belt stops slipping.

- **If you feel the belt is tight enough, but it still slips, the problem may be a loose Motor drive belt under the front cover.**

DO NOT OVERTIGHTEN – Over tightening will cause belt damage and premature bearing failure.

TREADBELT TRACKING ADJUSTMENT:

The performance of your treadmill is dependent on the frame running on a reasonably level surface. If the frame is not level, the front and back roller cannot run parallel, and constant belt adjustment may be necessary.

The treadmill is designed to keep the tread-belt reasonably centered while in use. It is normal for some belts to drift near one side while the belt is running with no one on it. After a few minutes of use, the tread-belt should have a tendency to center itself. If, during use, the belt continues to move toward one side, adjustments are necessary.

TO SET TREADBELT TRACKING:

A 8 mm Allen wrench is provided to adjust the rear roller. Make tracking adjustments from the **left** side only. Set belt speed at approximately 3 to 5 kph.

Remember, a small adjustment can make a dramatic difference!

Turn the bolt clockwise to move the belt to the right. Turn the bolt only a 1/4 turn and wait a few minutes for the belt to adjust itself. Continue to make 1/4 turns until the belt is stabilized and the edge is within between step rails.

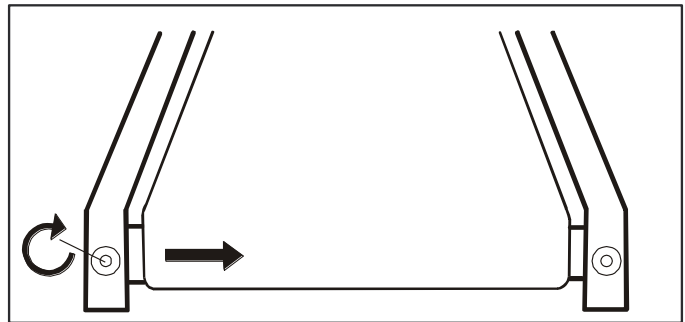

The belt may require periodic tracking adjustment depending on use and walking/running characteristics. Some users will affect tracking differently. Expect to make adjustments as required to center the tread-belt. Adjustments will become less of a maintenance concern as the belt is used. Proper belt tracking is an owner responsibility common with all treadmills.

ATTENTION:

DAMAGE TO THE RUNNING BELT RESULTING FROM IMPROPER TRACKING / TENSION ADJUSTMENTS IS NOT COVERED UNDER THE SPIRIT WARRANTY.

Unplug treadmill before performing any maintenance.

Task	How To	Daily	Weekly	Monthly	Semi-Annually	Annually
Wipe down unit	Damp cloth w/ water	•				
Clean under belt	Towel or vacuum			•		
Check belt tension/tracking	Feel/visual		•			
Clean under motor cover	Vacuum carefully				•	
Check hardware	Wrench			•		
Inspect for deck wear	Visual				•	
Inspect drive belt	Visual				•	

RECOMMENDED MAINTENANCE OF RUNNING BELT/DECK

Total Using Distance	20,000 Km/ 12,500 Miles	40,000 Km/ 25,000 Miles
Tasks	Flipping Deck	Replacing Belt and Deck

Note:

- Please clean wax on roller during flipping deck or replacing belt/belt.
- The low maintenance (routine monthly cleaning), dual-sided hard wax deck is designed to withstand up to 20,000 Kilometer/12,500 Miles on each side. If the original side of the deck shows significant wear, it needs to be flipped. Contact your service technician for assistance. Do not apply any type of lubricant or wax to the surface.

TROUBLESHOOTING

Before contacting your dealer for aid, please review the following information. It may save you both time and expense. This list includes common problems that may not be covered under the treadmill's warranty.

PROBLEM	SOLUTION/CAUSE
Display does not light	1) Tether cord not in position. 2) Circuit breaker on front grill tripped. Push circuit breaker in until it locks. 3) Plug is disconnected. Make sure plug is firmly pushed into 230 Vac wall outlet. 4) Breaker panel circuit breaker may be tripped. 5) Treadmill defect. Contact your dealer.
Treadmill belt does not stay centered Treadmill belt hesitates when walking/run on	The user may be walking while favoring or putting more weight on either the left or right foot. If this walking pattern is natural, track the belt slightly off-center to the side opposite from the belt movement. See General Maintenance section on Treadbelt Tension. Adjust as necessary.
Motor is not responsive after pressing start	1. Reset power. If still no good contact service.
Treadmill will only achieve approximately 7mph/10 kph but shows higher speed on display	This indicates motor should be receiving power to operate. Do not use an extension cord. If an extension cord is required it should be as short as possible and heavy duty 12AWG/2mm ² minimum, low voltage. Contact an electrician or your dealer. A minimum of 230 Vac current is required.
Treadmill trips on board 230V/15amp circuit	High belt/ deck friction. See General Maintenance section on cleaning the deck. If cleaning doesn't prevent this from reoccurring, check to see if there is significant wear of the deck. If so, the deck may need to be flipped if it is on its original side.
Computer shuts off when console is touched (on a cold day) while walking/running	Treadmill may not be grounded. Static electricity is "crashing" the computer. Refer to Grounding Instructions
Circuit breaker trips, but not the treadmill circuit breaker.	Check that the treadmill is the only appliance in the circuit. See "Important Electrical Information" in the front of this manual for more details.

PARTS LIST

Part NO.	Part Description	Q'ty
1	Main Frame	1
2	Incline Bracket	1
3	Console Mounting Bracket	1
4	Handpulse Assembly	1
5	Handrail (R)	1
6	Handrail (L)	1
7	Right Upright	1
8	Left Upright	1
10	AC Motor	1
11	Front Roller W/Pulley	1
12	Rear Roller	1
13	AC Incline Motor	1
14	Running Deck	1
15	Running Belt	1
17	Motor Inverter	1
18	AC Power Filter	1
19	Leveling Foot Pad	2
20	Drive Belt	1
21	Interface Board Bracket	1
22	Inverter Board	1
23	Copper Bushing	2
24	Transportation Wheel	4
29	Aluminum Side Rail	2
30	Step Rail	2
31	Inverter Support Bracket	1
32	Motor Insulator	2
33	Motor Insulating bushing	4
34	Interface Dummy Bracket	1
35	Cushion A	2
35-01	Cushion B	4
36	Running Deck Bracket	2
37	Motor Top Cover	1
38	Motor Bottom Cover	1
39	Frame Base Cover (R)	1
40	Frame Base Cover (L)	1
41	Rear End Cap (R)	1
42	Rear End Cap (L)	1
43~01	Beverage Holder Cover	1
43~02	Beverage Holder Inner Cover	1
43~05	3.5 × 12m/m Sheet Metal Screw	4
44	Beverage Holder Cover(Bottom)	1
45	Handrail Cover Inner (R)	1
46	Handrail Cover Outer (R)	1
47	Handrail Cover Inner (L)	1
48	Handrail Cover Outer (L)	1
49	Console Chin Cover (Front)	1

Part NO.	Part Description	Q'ty
50	Console Cover (Rear)	1
51	M3 × 5m/m_Phillips Head Screw	7
52	Safety Key	1
53	Step Rail Rear Support Plate	2
54	Console Assembly	1
55	30m/m_Handpulse Assembly	2
56	450m/m_Connecting Wire (Black)	1
57	AC Power Input Module	1
58	Motor Cover Plate	1
59	M10 × 50m/m_Hex Head Bolt	4
60	3/8" × 1" _Hex Head Bolt	4
61	M10 × 65m/m_Hex Head Bolt	1
62	M10 × P1.5 × 25m/m_Socket Head Cap Bolt	4
63	M10 × P1.5 × 35m/m_Socket Head Cap Bolt	6
64	M10 × P1.5 × 45m/m_Socket Head Cap Bolt	1
65	M10 × P1.5 × 60m/m_Socket Head Cap Bolt	10
66	M10 × P1.5 × 75m/m_Socket Head Cap Bolt	2
67	M8 × P1.25 × 12m/m_Flat Head Bolt	8
68	M5 × P0.8 × 12m/m_Phillips Head Screw	48
69	M5 × P0.8 × 25m/m_Phillips Head Screw	4
70	M4 × P0.7 × 12m/m_Phillips Head Screw	2
71	M10 × P1.25 × 8T_Nyloc Nut	6
72	M8 × P1.25 × 6.5T_Nyloc Nut	8
74	Ø3/8" × Ø25 × 3T_Flat Washer	18
75	Ø5.5 × Ø19 × 1.5T_Flat Washer	8
76	Ø3/8" × Ø30 × 3T_Flat Washer	8
77	Ø16.5 × Ø30 × 3T_Flat Washer	4
79	Ø10 × 2T_Spring Washer	25
80	Ø8 × 1.5T_Spring Washer	8
82	Ø5 × 15m/m_Sheet Metal Screw	6
83	Ø3.5 × 12m/m_Sheet Metal Screw	39
84	Ø3 × 20m/m_Tapping Screw	4
86	M6 × P1.0 × 35L_Flat Head Bolt	8
88	M16 × P2.0 × 55m/m_Socket Head Cap Bolt	2
89	M16 × 16T_Nyloc Nut	2
90	M8 × P1.25 × 140m/m_Socket Head Cap Bolt	8
92	M5 × 5T_Nyloc Nut	2
93	M5 × 12m/m_Phillips Head Screw	2
94	Ø10 × Ø25 × 2.5T_Nylon Washer	3
95	M3 × 0.5 × 6L_Plastic Screw	4
96	Isolation Column	4
97	450m/m_Connecting Wire (White)	1
98	300m/m_Ground Wire	1
99	800m/m_Handpulse Wire(SMP3)	1
100	800m/m_Handpulse Wire(SMR4)	1
101	400m/m_Connecting Wire	1

Part NO.	Part Description	Q'ty
102	350m/m Connecting Wire(XHP-7)	1
103	350m/m Connecting Wire(XHP-8)	1
104	2500m/m Computer Cable	1
105	Interface Board	1
107	800m/m Keyboard Wire	1
109	300m/m Connecting Wire	1
110	L Allen Wrench	1
111	Phillips Head Screw Driver	1
112	Short Phillips Head Screw Driver	1
118	2500m/m CSAFE Connecting Wire	1
123	Power Cord (Optional)	1
126	500m/m Ground Wire	1
127	Board	1
128	200m/m Handpulse Wire	1
131	M10 × P1.5 × 50m/m Hex Head Bolt(15L)	1
133	M5 Star Washer	4
135	M5 × P0.8 × 20L Plastic Screw	4
136	Pad	4
138	Ø4 × Ø10 × 1T Flat Washer	1
139	Choke	1
140	M5 × 6m/m Phillips Head Screw	3
141	Ø17 × Ø28 × 2T Nylon Washer	2
142	450m/m Connecting Wire (220V USE)	1
143	200m/m Keyboard Wire	1
144	Beverage Holder Pad(Upper)	2
156	M10 × P1.5 × 60m/m Hex Head Bolt	1
157	WFM-1012-06 Bushing	1
158	M5 × P0.8 × 10m/m Phillips Head Screw	8
159	M5 × 15mm Phillips Head Screw	4